



Dongguan Zhiding Electronics Technology Co., LTD

No. 8, Yinling Industry Zone, Xiaqiao, Dongcheng District,

Dongguan, Guangdong, China

Tel:86-0769-22665151 Fax:86-0769-22665155 Contact: Elsa Xiao Email: sales@zhidingled.com

---

## **Warm white 3535 led 80 CRI high lumen**

Good performance high CRI China manufacturer SMD 3535 warm white led and full colors.

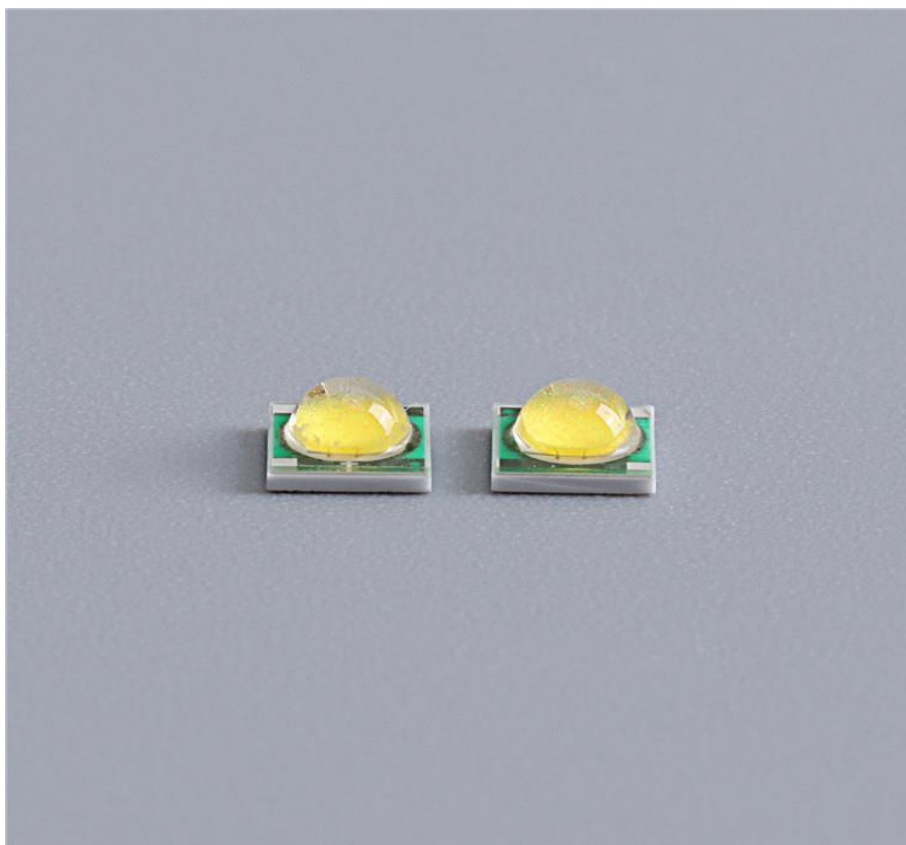

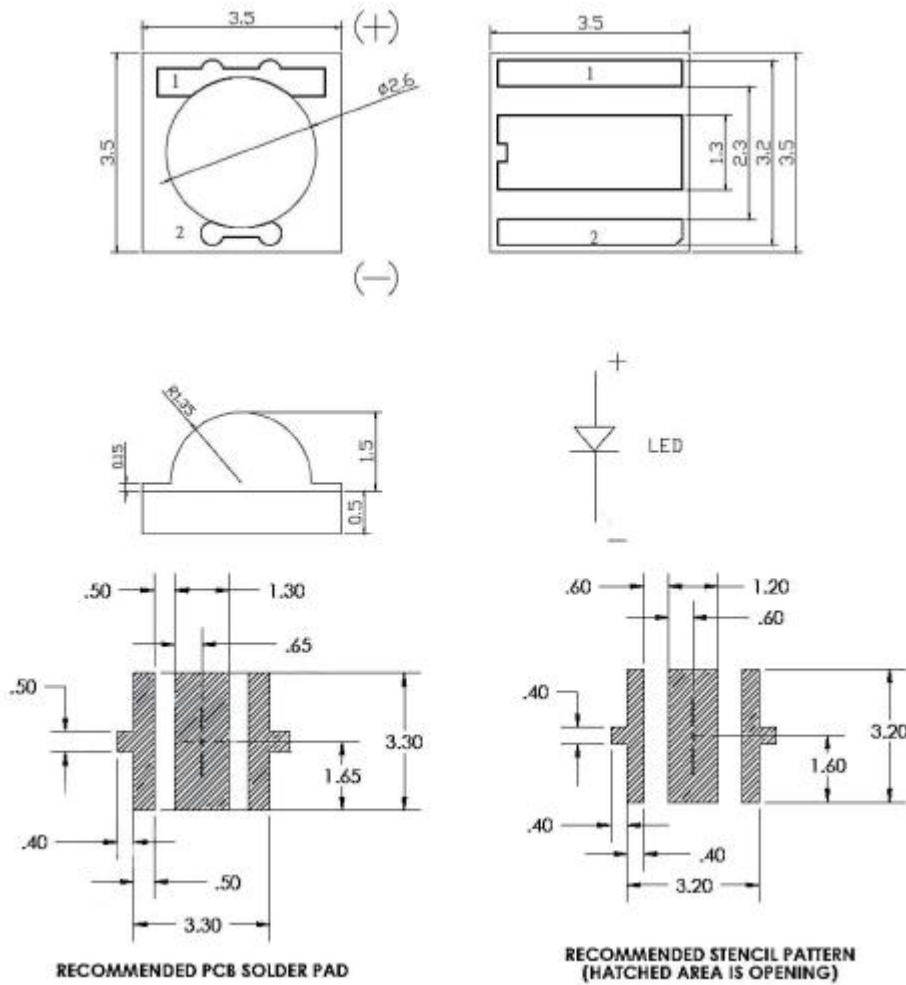

## Product Details

Size: 3.5\*3.5\*2.0mm with lens

- 1.High Lumens Output & Low Brightness Decay
- 2.Stable Performance & Great CCT
- 3.Wid Color Temperature Range
- 4.High CRI More Than 80 available
- 5.good raw materials
- 6.Bridgelux 45mil and Epileds 45mil chips

## smd 3535 warm white led Technical Data sheet

Absolute Maximum Ratings (TA=25°C)

IFP Conditions : 1/10 Duty Cycle, 0.1 msec Pulse Width.

Parameter	Symbol	Maximum	Unit
Power Dissipation	Pd	3000	mW
Peak Forward Current(Duty 1/10 @ 1KHz)	I <sub>FP</sub>	1500	mA
Forward Current	I <sub>F</sub>	700	mA
Reverse Voltage	V <sub>R</sub>	5	V

Operating Temperature Range		Topr	-40 C to + 85 C
Storage Temperature Range		Tstg	- 40 C to + 100 C
Model No.	AL-S3535WWO	Power	1W
Voltage	2.8-3.6V	Current	350mA
Chip Brand	Taiwan Chip	Chip Size	45mil
Color	Warm White	Lumens	90-120lm
Lifespan	50,000 hours	Warranty	2 years

### Precautions in Use:

Reflow profile

Soldering condition

Recommended soldering conditions

Reflow Soldering		Hand Soldering	
Pre-heat	160-180C	Temperature	300C Max.
Pre-heat time	120 seconds Max.		
Peak temperature	260C Max.	Soldering Time	3 seconds Max. (on time only)
Soldering Time	10 seconds Max.		
Condition	Refer to Temperature-profile		

We use the formal Epistar/Bridgelux/Epileds chip, 99.99% gold wire and copper base, Dow Corning glue, US Intermatix phosphors. High power SMD LED 3535 available in White Blue Red Green and Yellow color, 1W 3W as choose.

### Company Information

Dongguan Zhiding Electronics Technology Co., Ltd is an ISO Certificated manufacturer of high quality, high reliability electronic components, formed in January of 2009. Our staff has over 10 years of experience with excellent English. All of our employees have a strong work ethic and a strong commitment to provide the high quality products that consistently meet or exceed our customer's requirements.

### Our Advantages

Own the LED special dust-free, anti-static workshop.

Formed a number of world-class United States ASM automatic machine crystalline solid.

ASM automatic soldering machines, H120 automatic LED light colour scanner.

100% sure our quality is best, more detail please check below.



We have advanced testing equipment, can be "normal temperature continuous light lifetest", "high temperature and high humidity cycle test", "cold and hot shock cycle test" and "high and low temperature storage test", "high temperature continuous light test", "salt spray test" and reliability test, for all kinds of product reliability test of periodic on a regular basis, provides the high quality for our product quality assurance.



We are led manufacturer, have all series leds: Dip diode LED, SMD LED, High power LED, UV LED, IR LED. We are glad to recieve your inquiry!

**WELCOME TO CONTACT US>>>>WWW.ZHIDINGLED.COM**



Oversea Sales Manager  
Elsa Xiao  
E-mail:sales@zhidingled.com  
Skype: elsa.xiao0418  
Mobile: 86-13412570091  
WhatsApp: 86-13412570091  
Tel: 86-769-22665151  
Fax:86-769-22665155